

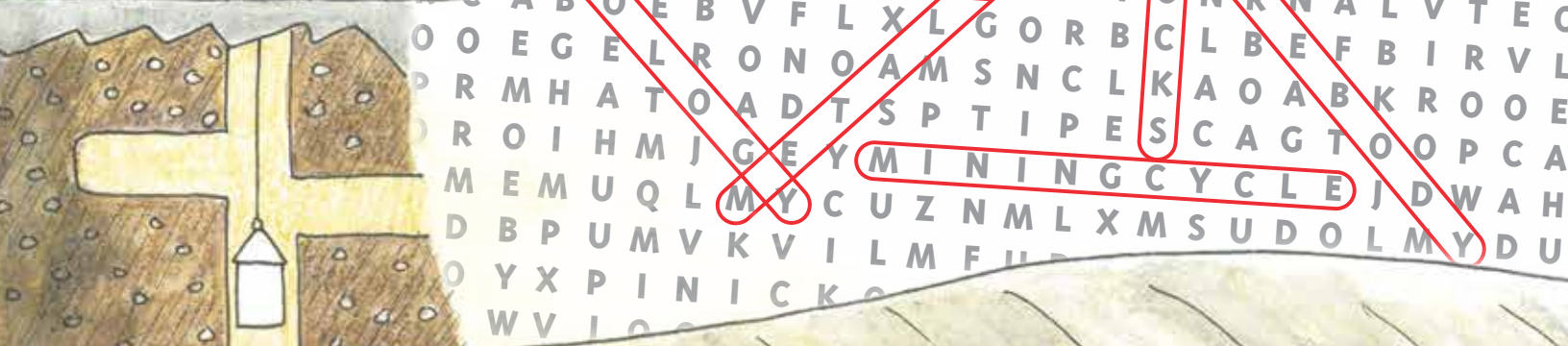

Activity Book

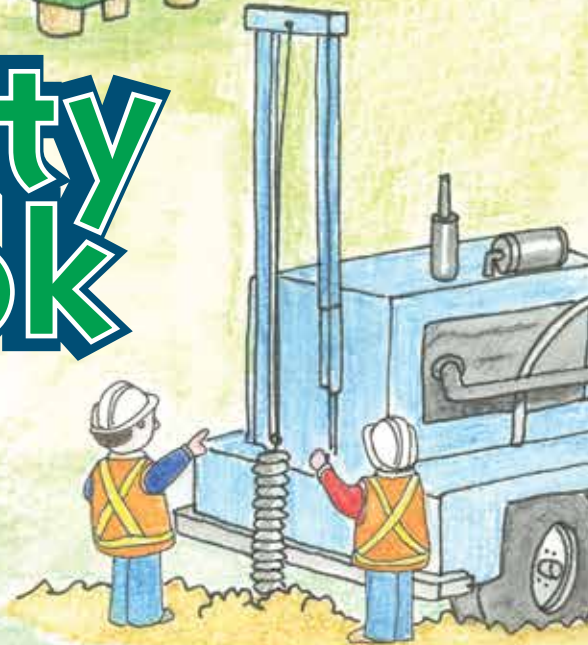

Cover Images

The phases of the mining cycle, from exploration to reclamation, are represented by the pictures on the front and back cover of this activity book.



Mining Matters is a charitable organization dedicated to bringing awareness about Canada's geology and mineral resources to students, educators and the public.

The organization provides current information about rocks, minerals, metals, mining and the diverse career opportunities available in the minerals industry.

www.miningmatters.ca

Charitable Registration Number
88775 6435 RR0001



mining MATTERS

Activity Book

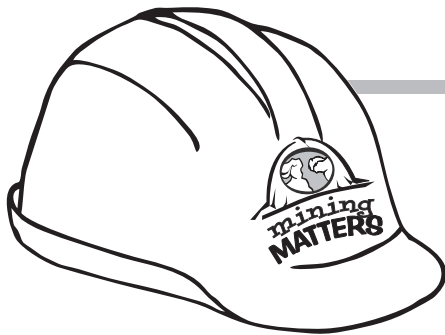

**Grab your hard hat
and get ready to dig into
a mine load of fun!**

Packed with puzzles, the **Mining Matters Activity Book** includes codes to crack, things to spot, word searches, crosswords and more.



Discover the three rock groups and the properties of minerals. Be surprised when you learn that rocks, metals and minerals are in the everyday things around you, from your food, medicine and toothpaste to your cellphone, computer and home.

Find out how geologists explore for treasures of the Earth and how engineers go about building a mine. Explore exciting careers in the mining industry.

Be proud that Canada is a world leader in the mining industry. Discover why **Mining Matters**, and have fun doing it!

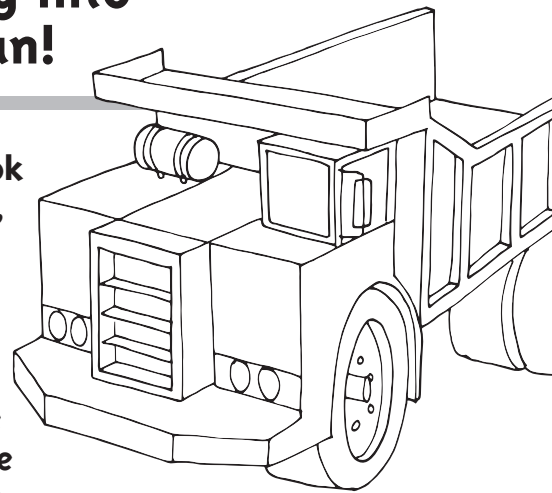
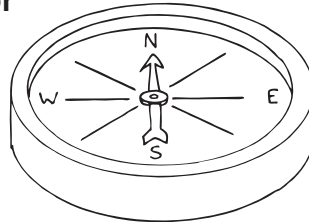

Navigate to the Surface



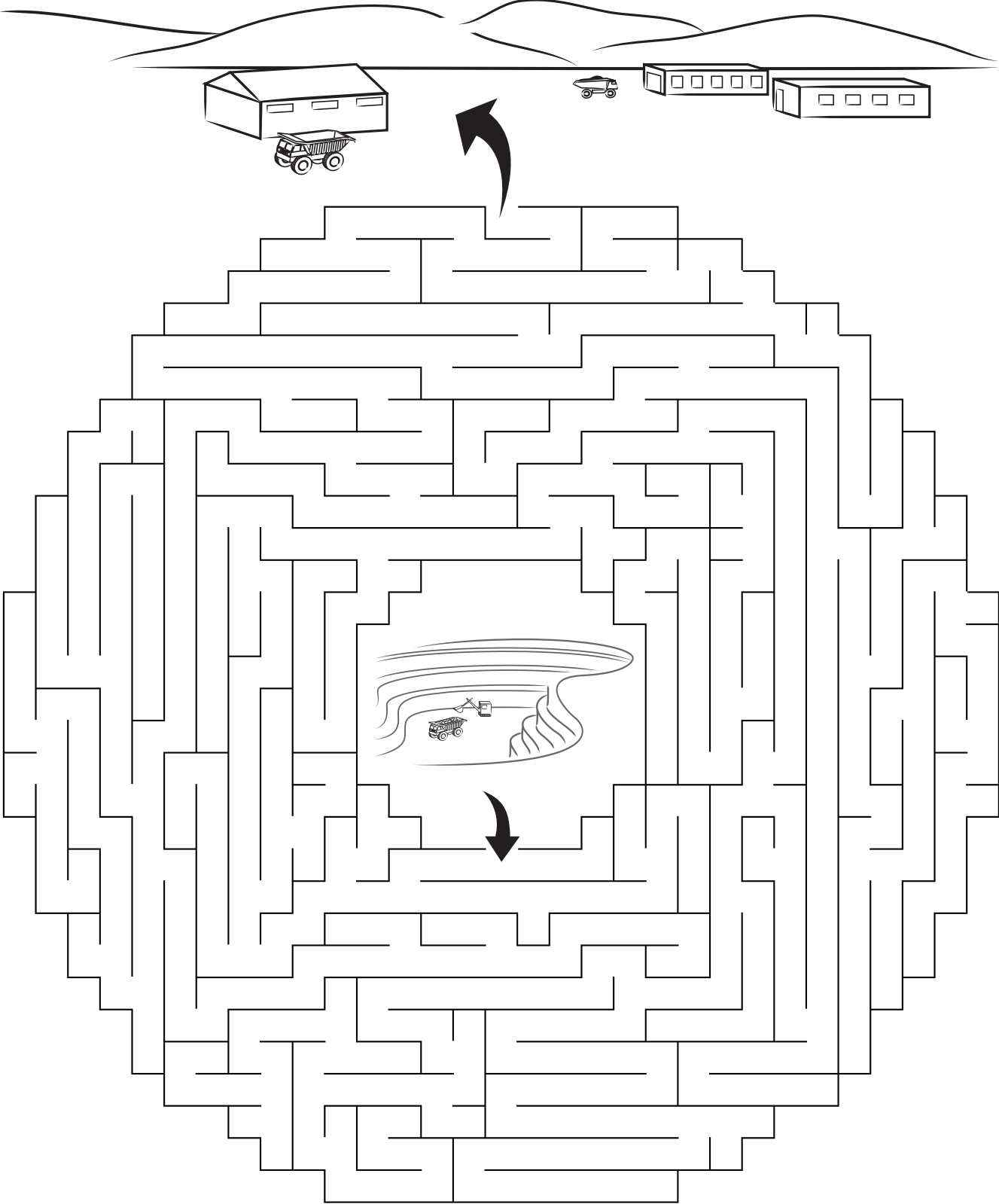

Help the mining truck driver haul the ore out of the surface mine and deliver it to the processing plant. Ore is a rock that contains a valuable metal or mineral.

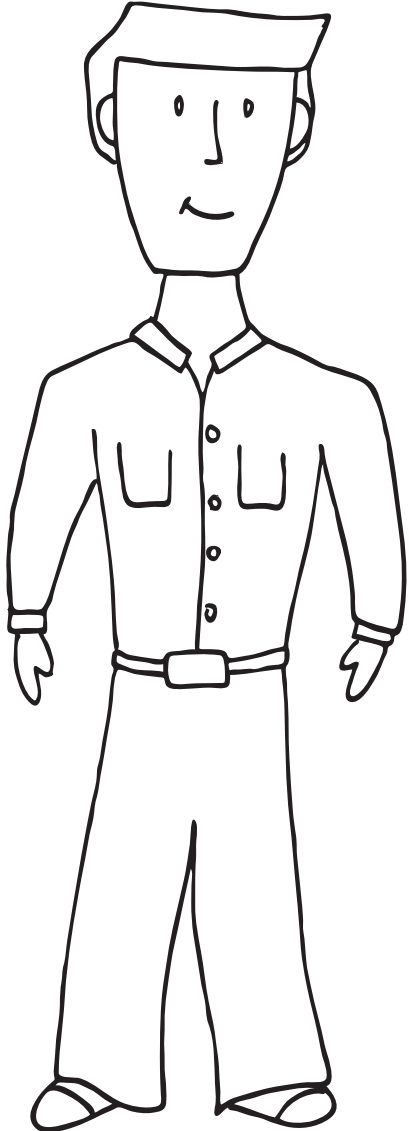
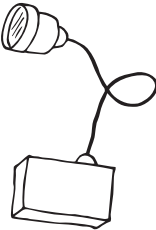
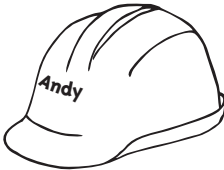
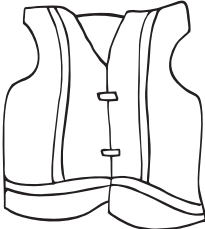

Safety Dress Up

Canada is a world leader in the mining industry. Safety is the industry's number one most important practice. Help Andy get dressed for a day at the underground mine site in his Personal Protective Equipment (PPE).

Match the correct words with the safety equipment, and then match the equipment to Andy.

<input type="checkbox"/>		<input type="checkbox"/>		
Safety Gloves	<input type="checkbox"/>			<input type="checkbox"/>
Ear Muffs	<input type="checkbox"/>			<input type="checkbox"/>
Hard Hat	<input type="checkbox"/>			<input type="checkbox"/>
Head Lamp and Battery Pack	<input type="checkbox"/>			<input type="checkbox"/>
Safety Glasses	<input type="checkbox"/>			<input type="checkbox"/>
Safety Boots	<input type="checkbox"/>			<input type="checkbox"/>
Safety Vest	<input type="checkbox"/>			

Draw the Mining Truck

Mining trucks can hold up to 450 tonnes of ore. That is approximately the weight of 250 cars! The tires can be up to 3.5 metres tall. It takes a lot of power to move these trucks. The wheels are so big that there is a motor for each one.

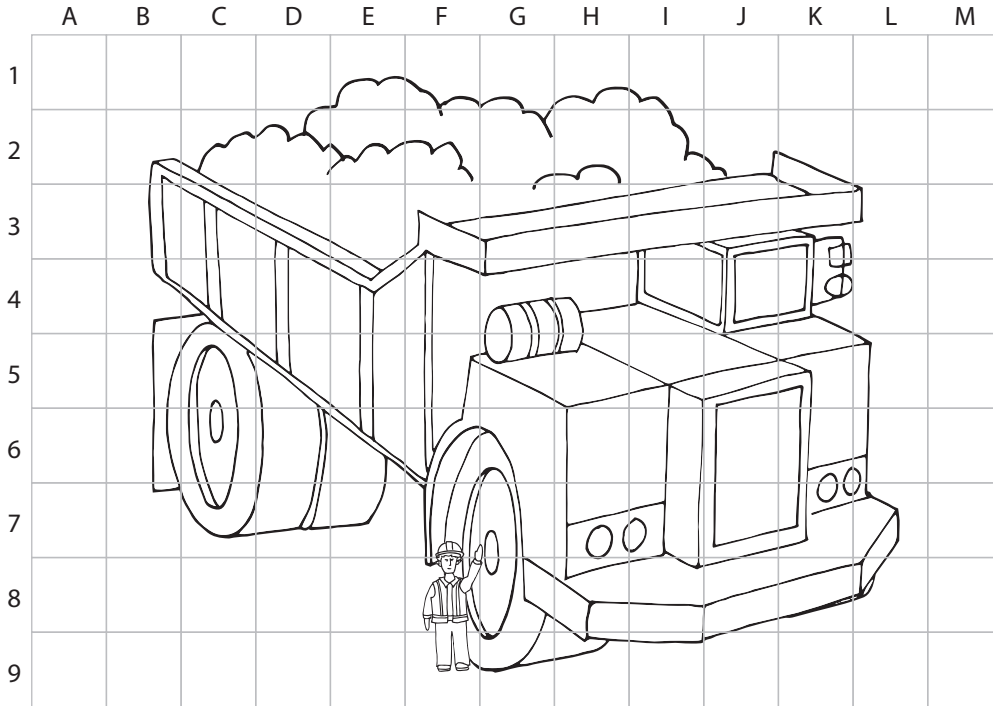

Draw and colour the mining truck using the grid below.

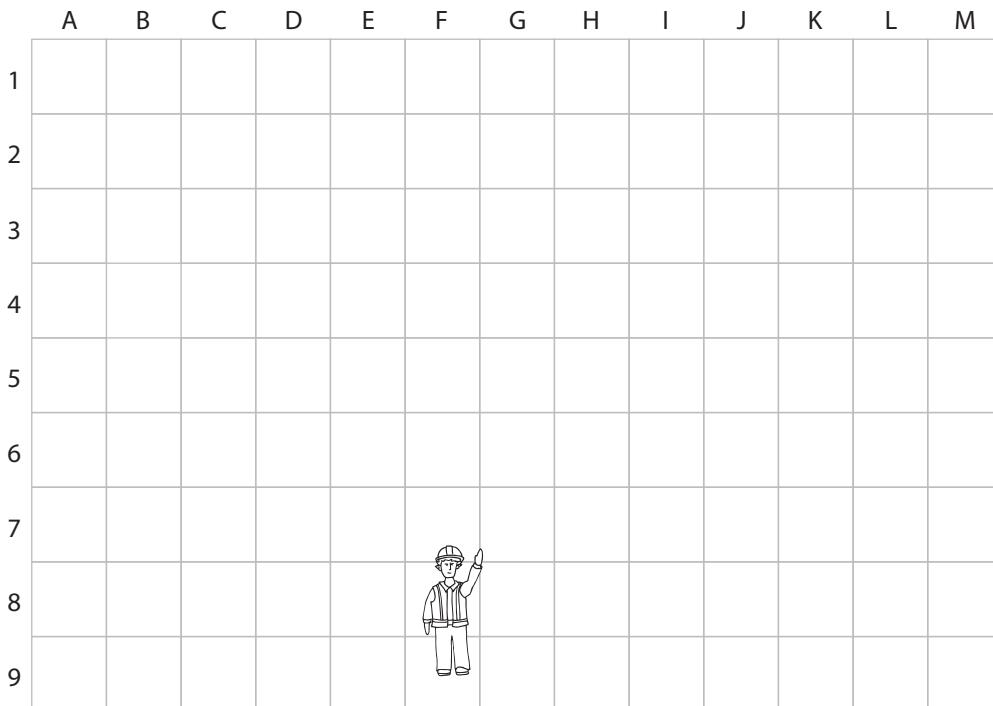
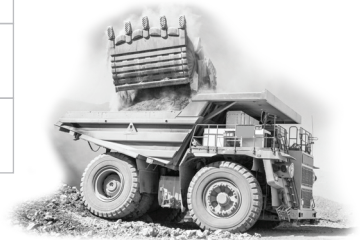

Dig Deep

MINING is a temporary use of the land during which valuable rock containing metal or minerals, called an **OREBODY**, is removed from the Earth. An **UNDERGROUND MINE** is created when deep tunnels are dug to reach an orebody. The main vertical tunnel is called a **SHAFT**. At its top is a wood, steel or concrete **HEADFRAME** containing a **SHEAVE** (pulley system) that is attached to an elevator or **CAGE** to transport the miners and equipment from the surface to the underground workings. The sheave also supports a bucket or **SKIP** to lift the broken rock and ore to the surface.

Other vertical tunnels called **VENTILATION SHAFTS** bring fresh air to the mine. From the shaft, horizontal tunnels called **DRIFTS** provide access to the orebody. **EXPLOSIVES** break up the rock so it can be picked up by a low, narrow truck with a bucket up front, called a **SCOOPTRAM**. It is driven to the shaft and the ore is dumped into the skip, which brings it to the surface.

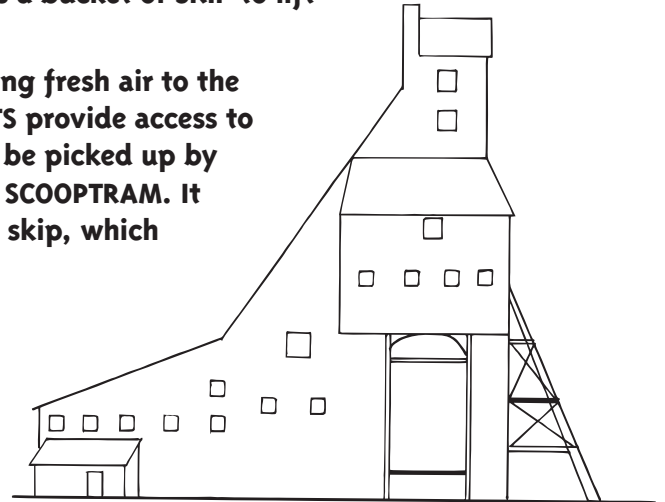

Can you find the words associated with underground mining? Words can be found in any direction.

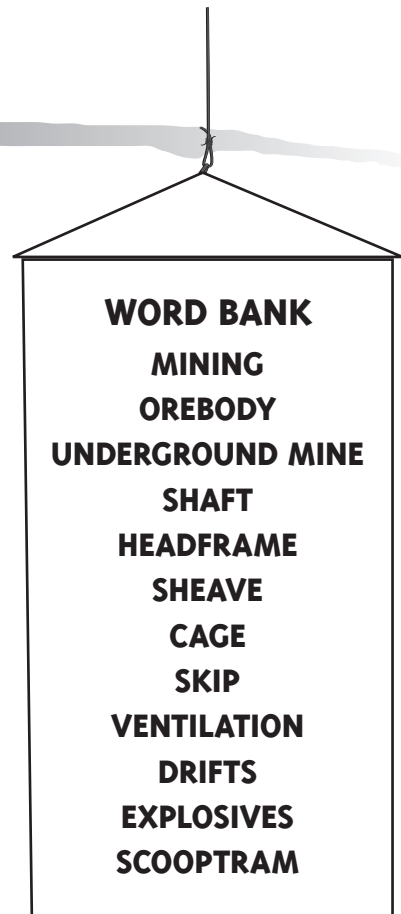

Compass Code Puzzle

Compasses have been used for hundreds of years to find directions. Nowadays, complex equipment like a GPS (Global Positioning System) is used along with compasses to accurately pinpoint locations.

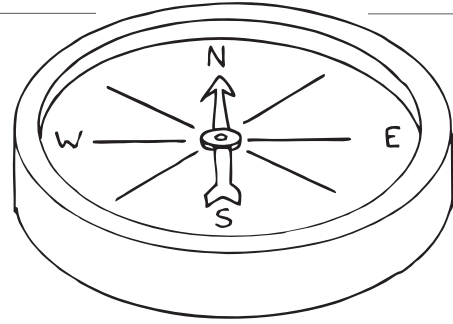

I	A	B	O	T	C
F	I	S	N	G	R
H	T	I	J	W	O
K	M	S	I	N	L
P	I	I	T	Q	U
E	N	V	X	B	L
D	W	Y	Z	N	G

Use the compass directions to find a message in the puzzle. Start at the letter "I" in the top left corner of the puzzle and follow directions shown under each letter space at the bottom of the page.

Mineral Properties

Geologists use a number of tests to determine the physical properties of minerals. Those properties help to identify the mineral.

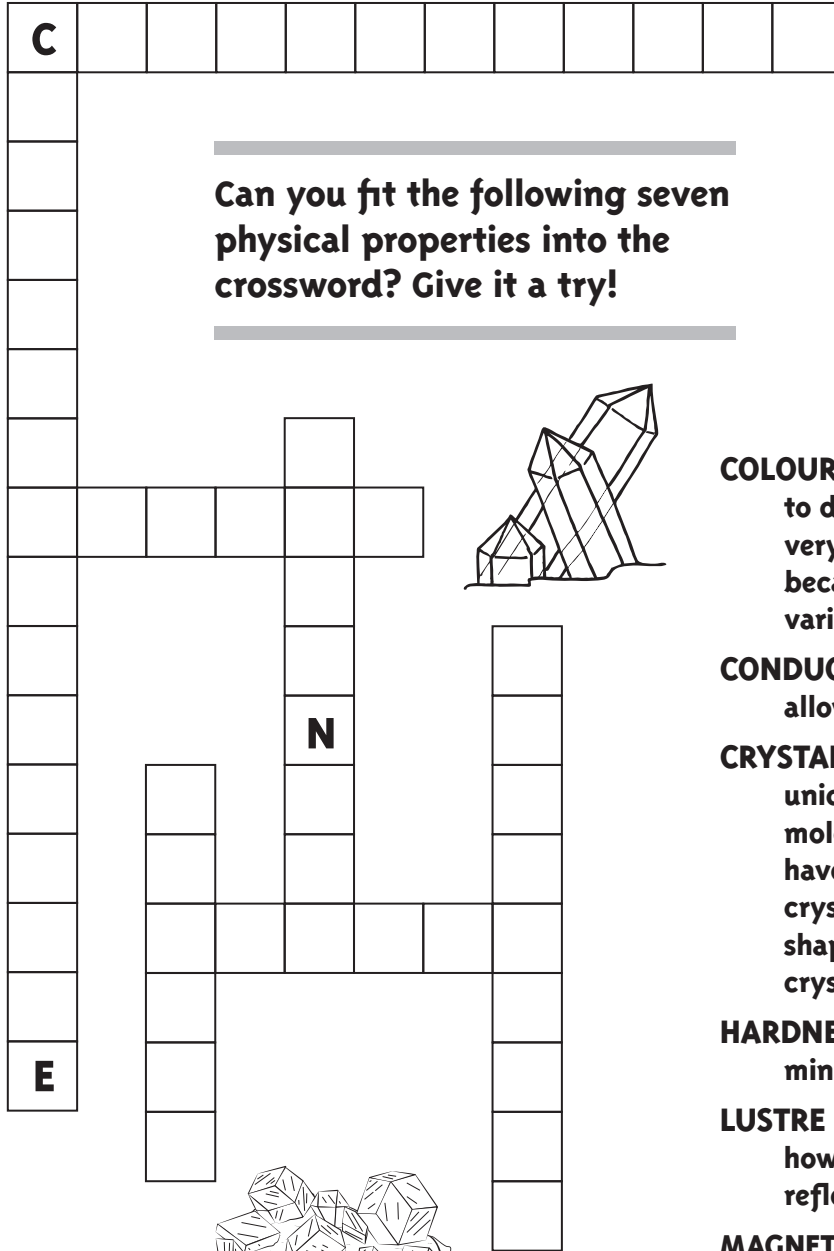

Can you fit the following seven physical properties into the crossword? Give it a try!

WORD BANK

COLOUR
 CONDUCTIVITY
 CRYSTAL STRUCTURE
 HARDNESS
 LUSTRE
 MAGNETISM
 STREAK

COLOUR is a property commonly used to describe minerals, but it is not a very good one to use to identify them because many minerals come in a variety of colours.

CONDUCTIVITY is the property that allows a mineral to conduct electricity.

CRYSTAL STRUCTURE is the property of a unique arrangement of atoms, ions or molecules in a mineral. When minerals have the time and space to “grow” or crystallize, they can develop regular shapes and patterns because of crystal structure.

HARDNESS is the property that allows a mineral to resist being scratched.

LUSTRE is the property that indicates how much the surface of a mineral reflects light.

MAGNETISM is the property that allows a mineral to attract or repel other magnetic materials.

STREAK is the property of colour when a mineral is in powdered form.

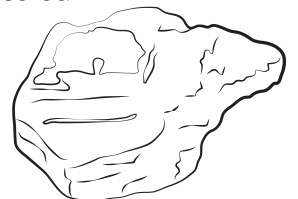
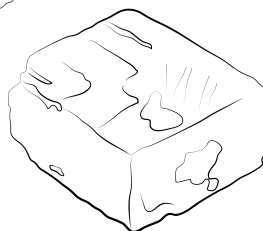
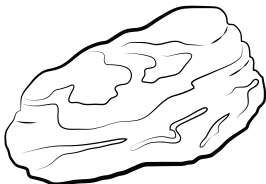
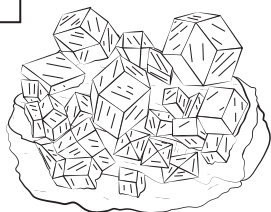

Wordoku

Fill in the grid so that every row, every column and every 3 x 3 box contains each of the nine letters seen below **ONLY ONCE**.

LETTERS: G, E, R, A, L, S, T, O, I

	R	I	O	T	E			A
S	E		G			R		I
	L	O	R	I			T	E
O	I			E		T		
E			T	O	I	A	R	
R		L		A		E	I	
			A	S	L		E	G
	A	E		G	T			R
I	S	G					A	T

What is the hidden nine-letter word in the diagonal from top left to bottom right?

Hint: This scientist studies materials, processes and the history of Earth. He or she helps locate and develop natural resources, and studies hazardous natural phenomena such as earthquakes, tsunamis, landslides and volcanoes.



Patty the Prospector

Learn about Patty's job as a prospector by filling in the blanks with the correct words from the word bank.



WORD BANK

ADVENTURE
DETECTIVE
EARTH
GOLD
GPS
ROCK HAMMER
SAFETY GLOVES
WOODS

As a prospector, Patty explores different regions of the _____, acting as a _____, trying to discover valuable mineral deposits such as copper, _____, or even diamonds. She uses her _____ to help find her way through the _____. She uses her _____ to break rock to collect samples. Patty always wears her safety boots, safety glasses and _____ to protect her from nature's elements. A day in the life of Patty the Prospector is always an _____!

Connect the Dots

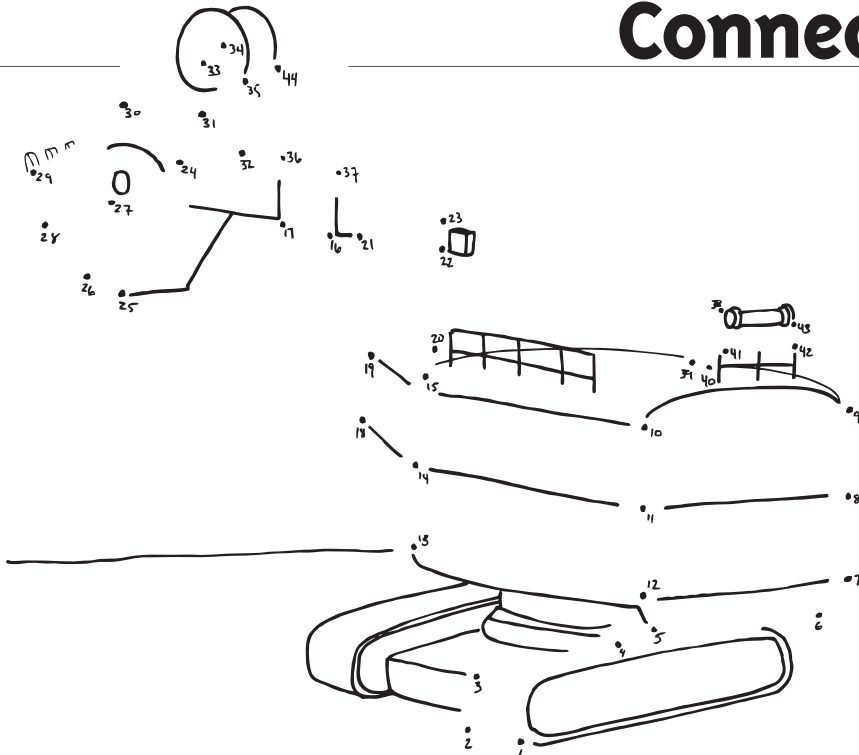

Connect the dots
to reveal this
piece of mining
equipment.

The Mining Process

The mining process is complicated and involves looking for minerals, evaluating a mineral discovery, building a mine, mining and processing minerals, closing the mine and reclaiming the land. From start to finish a mining company has to think about how its activities will affect the environment and nearby communities. The mining process can take a very long time and cost millions of dollars.

Can you put the pictures in order to tell the story of the mining process?

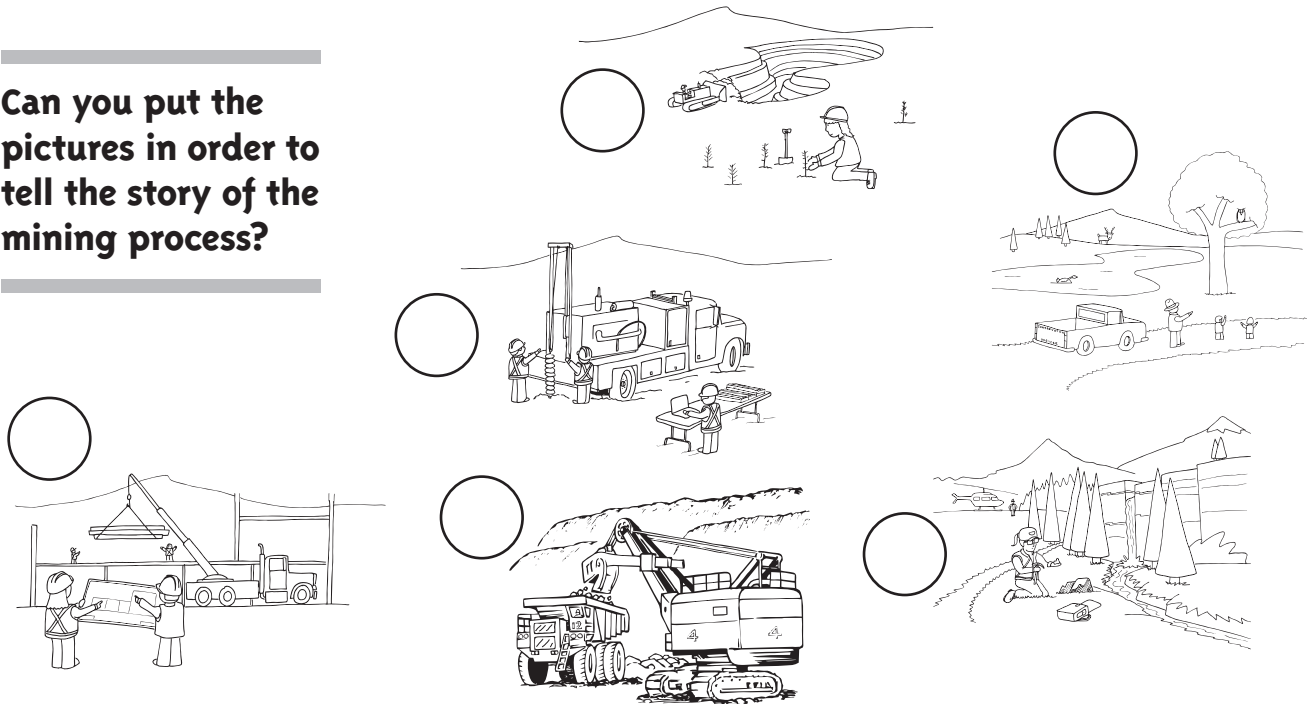

- A** **LOOKING FOR MINERALS**
Geologists do field work to identify different rocks, study satellite images of Earth and use airplanes or helicopters to measure things, such as magnetism in the underlying rocks.
- B** **EVALUATING A MINERAL DISCOVERY**
The company drills holes in the ground to take out long, thin cylinders of rock called core, which can be studied to find out how much valuable mineral they contain. The company determines how much it will cost to construct and operate the mine, to sell the minerals, to take care of the environment, and whether or not the company will make any money.
- C** **BUILDING A MINE**
Huge diggers scrape away the surface material and explosives are used to blast the solid rock to reach the valuable

minerals located close to the surface, or tunnels are dug into the Earth to reach valuable minerals buried deep below the surface. Roads, mineral processing plants, employee housing and offices are also constructed.

- D** **MINING AND PROCESSING MINERALS**
Miners use drills and explosives to break up the rock. Large scoops and machines move the rock to the processing plant where it is crushed into a fine powder and valuable minerals are separated from the waste rock.
- E** **CLOSING THE MINE**
Buildings are removed, pits and tunnels are made safe, the environment is protected from mine waste, and the land is replanted with grass and trees.
- F** **RECLAIMING THE LAND**
The land is made safe, usable and a natural part of the surrounding environment.

Minerals for our Bodies

There are 21 essential minerals that our bodies need to live active and healthy lives. The essential minerals in our bodies are the same elements that we mine out of the Earth and are also found in fruits, meats, vegetables, milk and vitamins.

Can you fit these 21 essential minerals into the crossword?

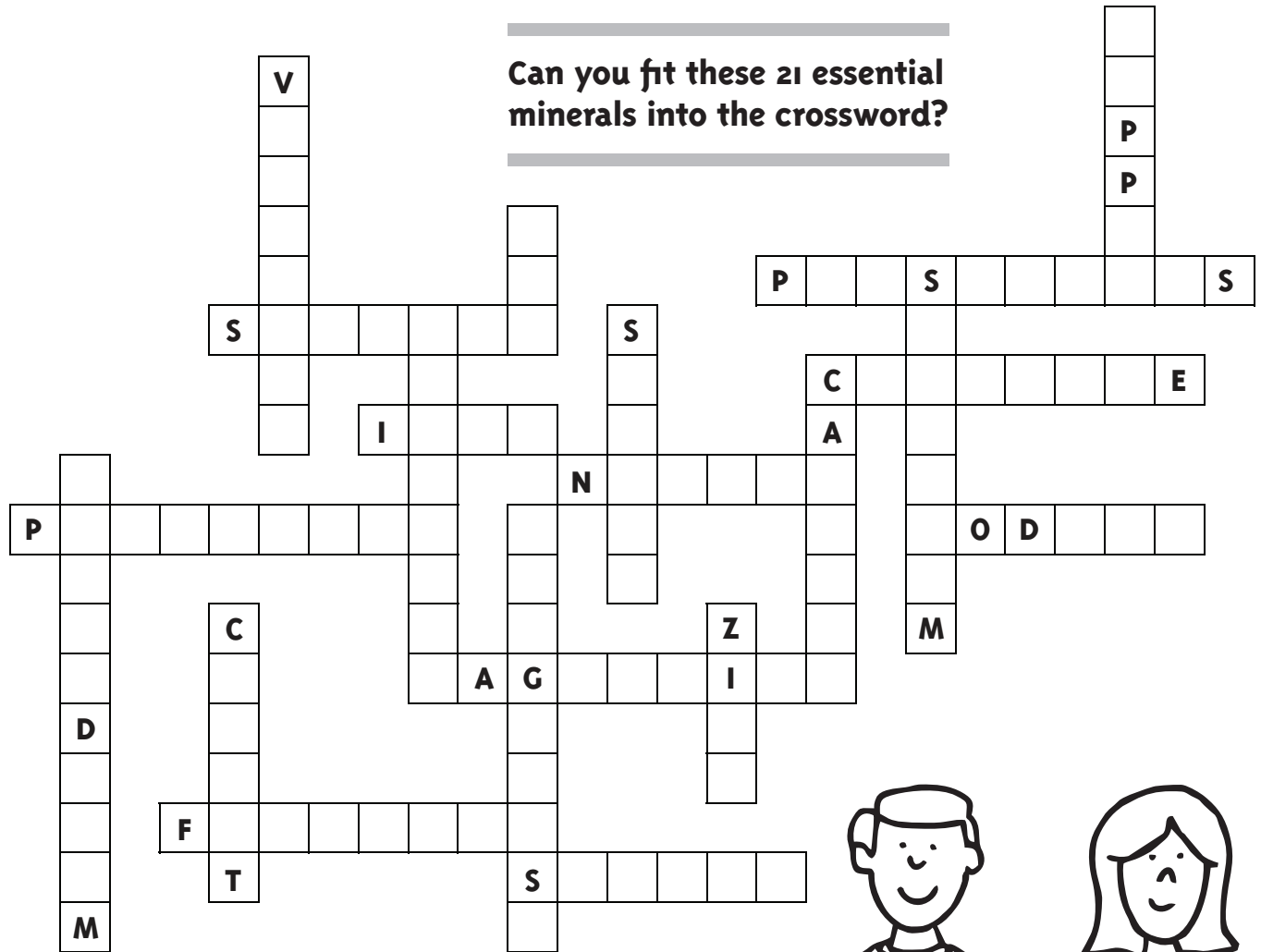

WORD BANK

CALCIUM
CHLORIDE
CHROMIUM
COBALT
COPPER
FLUORIDE
IODINE

IRON
MAGNESIUM
MANGANESE
MOLYBDENUM
NICKEL
PHOSPHORUS
POTASSIUM

SELENIUM
SILICON
SODIUM
SULFUR
TIN
VANADIUM
ZINC

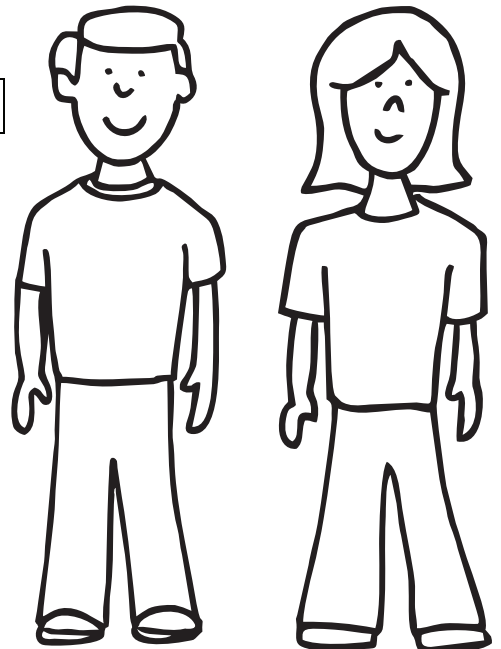

Hidden Word Sudoku

Fill in the grid so that every row, every column and every 3 x 3 box contains each of the nine numbers below **ONLY ONCE**.

		3	6	8	4			9
4	5		7			2		3
	8	9			2		1	4
3	9		4		6	8		
6			1	9		4	3	
2		1		7		5	9	
			2	6		9	4	5
	6	4		3	8			7
5	1	2			7		6	

What are the two hidden words in the diagonal from top left to bottom right?

Hint: This term describes the endless processes that create, change, destroy and recreate the three main groups of rocks – igneous, sedimentary and metamorphic.

1 = R 4 = K 7 = B
 2 = L 5 = O 8 = E
 3 = Y 6 = A 9 = C

Product Matching

Everything in our world that isn't grown is made using rocks, minerals, metals and petroleum resources that are extracted from the Earth. We use rocks, minerals, metals and petroleum to build homes and schools, to generate heat and power, and to make everyday comfort items like shampoo and toothpaste.

Minerals help our food grow too – you can find up to 14 minerals in fertilizer. Minerals and metals make our homes and buildings strong and safe – from the floors to the plumbing to the rooftop, construction materials are all based on minerals and metals. We even use minerals and metals to make life beautiful! There are minerals in paint and cosmetics, and we use metals to make jewellery and sculptures. Minerals and metals are also used to help keep our environment clean by improving our cars, and filtering the air we breathe and the water we drink.



GYPSUM

Gypsum is a soft, chalky, white mineral that is used to make drywall, plaster, cement and caulking.

MICA

Ground mica is a mineral used in wallpaper, paint, cosmetics, tiles and roofing – tiny flecks of mica give a sparkling effect.

HALITE

Halite is a mineral that adds flavour to food, melts ice on roads and is also used in the manufacture of glass, fire extinguishers, paint, plastics, synthetic rubbers and cosmetics.

CHALCOPYRITE

Chalcopyrite is a mineral containing copper. Copper is used in electrical wires, plumbing, coins and kitchen appliances, to name a few.

TALC

Talc is a very soft, powdery mineral used in making paper, paints, soap, cosmetics, fireproof roofing, pottery and insecticides.

CALCITE

Calcite is a mineral used in the manufacture of fertilizers, metals, glass, rubber, paint and cement. We also use it to help keep our teeth clean.

SPHALERITE

Sphalerite is a mineral containing zinc. Zinc is used to coat steel to prevent corrosion and is found in many common products including batteries, medicines, insect repellent and sunscreen.

LIMESTONE

Limestone is a rock used as a construction material; in making steel, glass and paper; in refining sugar; and to prevent water and air pollution.



Which mineral or rock is found in these everyday products?

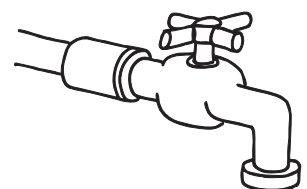
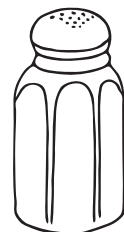

What's in your Computer?

Did you know we use minerals every day? The products of mining provide many essential items, including highways, electrical and communications networks and housing.

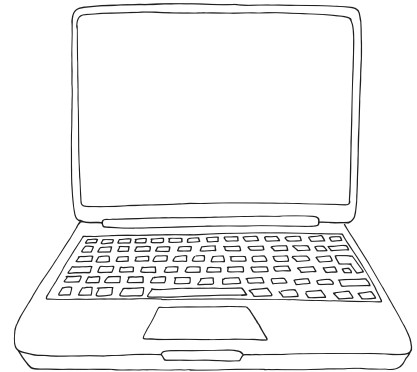

In the puzzle below, can you find the metals and minerals that make up computers, cell phones and most other high-tech gadgets?

WORD BANK

ALUMINUM	COPPER	GOLD	NICKEL	TIN	ZINC
CHROMIUM	GALLIUM	LEAD	SILVER	TITANIUM	
COBALT	GERMANIUM	LITHIUM	TANTALUM	TUNGSTEN	









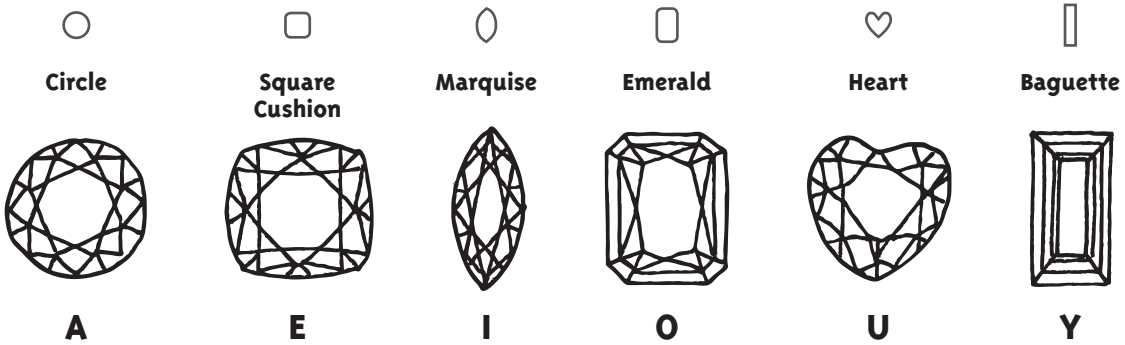



























J Z D W P J M C S I L V E R D B T B
 L O C R I U S R T T U O N N S I U J
 Q Z C H I J E B J I L M D S T B N R
 D X B L R C A R G E T V F L X T G U
 N T L X O O O G E R M A N I U M S X
 I A G I P B M F A T D V N D S P T B
 G N M O W R M I H M J U R I M B E C
 M T X X L M E M U Q L D W O U Z N O
 U A D O D D B P U M V K V R K M F B
 N L T L L O Y X P I N I C K E L H A
 I U L E A D W V J O C C J P U J N L
 M M G Z X K G C P H C G P C S I L T
 U O L E U S N D Y N H F P C T H E D
 L B Q F B I H L A Q I N S T B E L X
 A K T G Z O J V L I T H I U M I R V

Gemstone Month

Gemstones, also called precious or semi-precious stones, are cut and polished minerals used to make jewellery. Certain rocks (lapis lazuli) or organic material (amber) that are not minerals, are also used for jewellery and are therefore often considered to be gems as well. Each month has an official gemstone.

Can you unlock the key to figure out which gemstone belongs to each month in the calendar? There are six different popular gem shapes which represent a vowel in this challenge to help you get started.



January	_____	_____	_____	_____	_____	July	_____	_____	_____		
											
February	_____	_____	_____	_____	_____	August	_____	_____	_____		
											
March	_____	_____	_____	_____	_____	September	_____	_____	_____		
											
April	_____	_____	_____	_____	_____	October	_____	_____	_____		
											
May	_____	_____	_____	_____	_____	November	_____	_____	_____		
											
June	_____	_____	_____	_____	_____	December	_____	_____	_____		
											

WORD BANK

AMETHYST AQUAMARINE CITRINE DIAMOND EMERALD GARNET OPAL
PEARL PERIDOT RUBY SAPPHIRE TURQUOISE

Rocks, Minerals, Metals and Mining Word Search

Mining is one of Canada's most important economic sectors and a major job creator. Approximately 400,000 people across Canada work in mineral exploration, mining and mineral processing. Thanks to its rich geology, Canada is one of the largest mining nations in the world, producing more than 60 minerals and metals.

WORD BANK

AGATE	FELDSPAR	HALITE	METALS	RHYOLITE
AMETHYST	GABBRO	HEMATITE	MICA	ROCKS
BASALT	GEM	IRON	MINE	SANDSTONE
CADMIUM	GNEISS	LEAD	MINERALS	TIN
COPPER	GOLD	LIMESTONE	MINING	ZINC
CRYSTAL	GRANITE	MAGNETITE	NICKEL	
DIAMOND	GYPSUM	MARBLE	QUARTZITE	

Locate and circle all of the words from the word bank. Use the leftover letters to find a secret catch phrase.

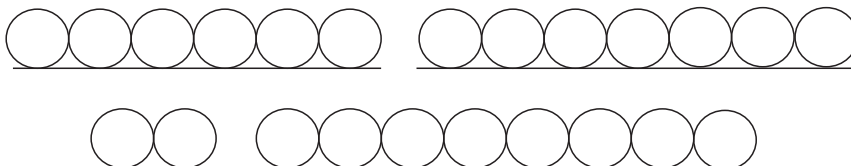
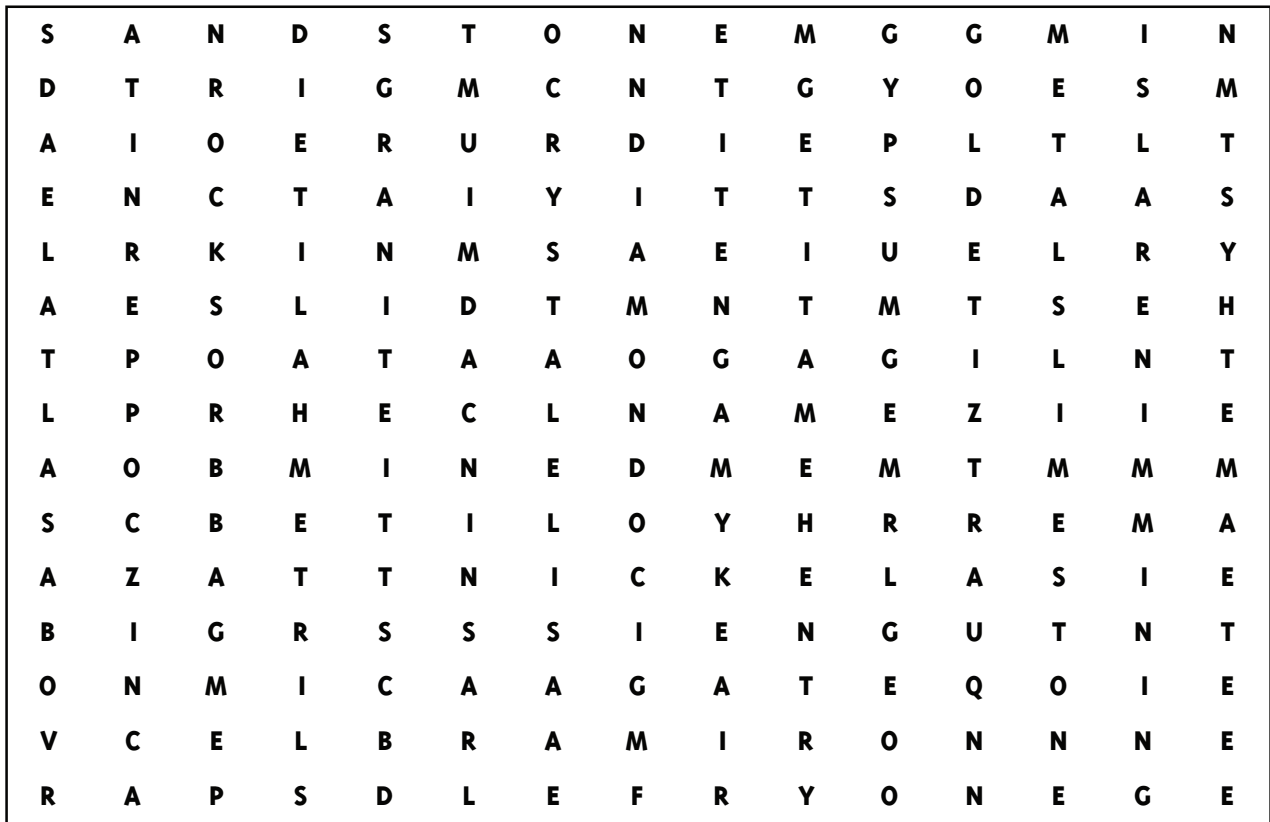

Geology Word Search

Geologists tell us the story of the Earth and help find important rock, mineral, metal and petroleum resources.

Find the geology words in the word search.

M	S	Q	V	R	Z	S	N	A	D	R	W	N	G	A
E	U	X	L	K	E	F	V	D	C	V	G	R	P	F
T	O	E	P	C	G	A	N	O	I	S	O	R	E	U
A	E	K	K	O	L	U	N	T	O	R	E	J	C	G
M	N	V	Y	R	A	T	N	E	M	I	D	E	S	N
O	G	X	W	T	I	G	X	K	O	O	S	U	A	I
R	I	J	Y	N	W	Y	I	R	O	C	K	S	V	R
P	K	A	E	X	T	R	U	S	I	V	E	R	L	E
H	S	N	M	I	N	E	R	A	L	S	U	J	K	H
I	T	E	L	E	M	E	N	T	S	T	E	T	U	T
C	K	E	C	W	I	N	T	R	U	S	I	V	E	A
M	E	L	O	N	V	Q	L	J	U	U	T	D	T	E
R	J	F	F	I	C	Z	Q	Q	M	A	G	M	A	W
D	E	G	E	O	L	O	G	Y	L	Q	V	H	M	D
W	O	N	A	C	L	O	V	Y	J	Z	G	V	O	J

GEOLOGY: Geology is the study of the Earth.

ELEMENTS: Elements are naturally occurring pure substances. They make up all matter, including minerals.

MINERALS: Minerals are made of elements that occur naturally.

ROCKS: Rocks are made up of two or more minerals.

SEDIMENTARY: One of three types of rocks. Sedimentary rocks are formed from the deposition of rocks, minerals or organisms.

IGNEOUS: One of three types of rocks. Igneous rocks are formed through cooling of lava or magma.

METAMORPHIC: One of three types of rocks. Metamorphic rocks are created by the transformation of existing rock through heat and pressure.

VOLCANO: An opening in the Earth's surface through which melted rock and gases escape.

CONTINENT: Large mass of land on Earth.

MAGMA: Melted rock deep beneath the Earth's surface.

LAVA: Melted rock that comes out of a volcano.

EXTRUSIVE Rock: A rock formed from lava that came out of a volcano.

INTRUSIVE Rock: A rock that cooled from magma deep under the Earth's surface.

WEATHERING: The breaking down of rocks into smaller and smaller pieces by the effects of weather.

EROSION: The movement of rocks, soil, minerals and other materials from their natural source to a different location, usually by wind, water and ice.

Rock Cycle Crossword

The rock cycle describes the endless processes that create, change, destroy and recreate the three main groups of rocks – igneous, sedimentary and metamorphic.

Use the clues to fill in the crossword.

ACROSS

- 2 Solid materials moved and deposited in a new location by water, wind or ice are called _____. Over time, layers of these can make sedimentary rock.
- 4 Molten rock that comes out from a volcano is called _____.
- 6 Fossils are found in this type of sedimentary rock.
- 9 This metamorphic rock forms from applying heat and pressure to limestone.
- 11 Water, wind and ice break down rocks in a process called _____.
- 12 This igneous rock forms through slow cooling of magma and sometimes has pink, white and black minerals in it.
- 14 This igneous rock forms from lava eruptions and sometimes has microscopic pink, white and black minerals in it.
- 16 Rocks change from one basic rock type to another in a process called the "rock _____."

DOWN

- 1 The name of this basic rock type means to "change" or to "transform."
- 2 This metamorphic rock forms from applying heat and pressure to shale.
- 3 This sedimentary rock forms from sand.
- 5 A person who studies the Earth.
- 7 Molten rock deep under the surface of the Earth is called _____.
- 8 Metamorphic rocks are formed by heat and _____.
- 10 The transport of rocks by wind, water and ice is called _____.
- 13 The name of this rock type is derived from the Latin word meaning "fire."
- 15 There are _____ basic type of rocks.

WORD BANK

CYCLE EROSION GEOLOGIST GRANITE IGNEOUS LAVA LIMESTONE MAGMA MARBLE
METAMORPHIC PRESSURE RHYOLITE SANDSTONE SEDIMENTS SLATE THREE WEATHERING

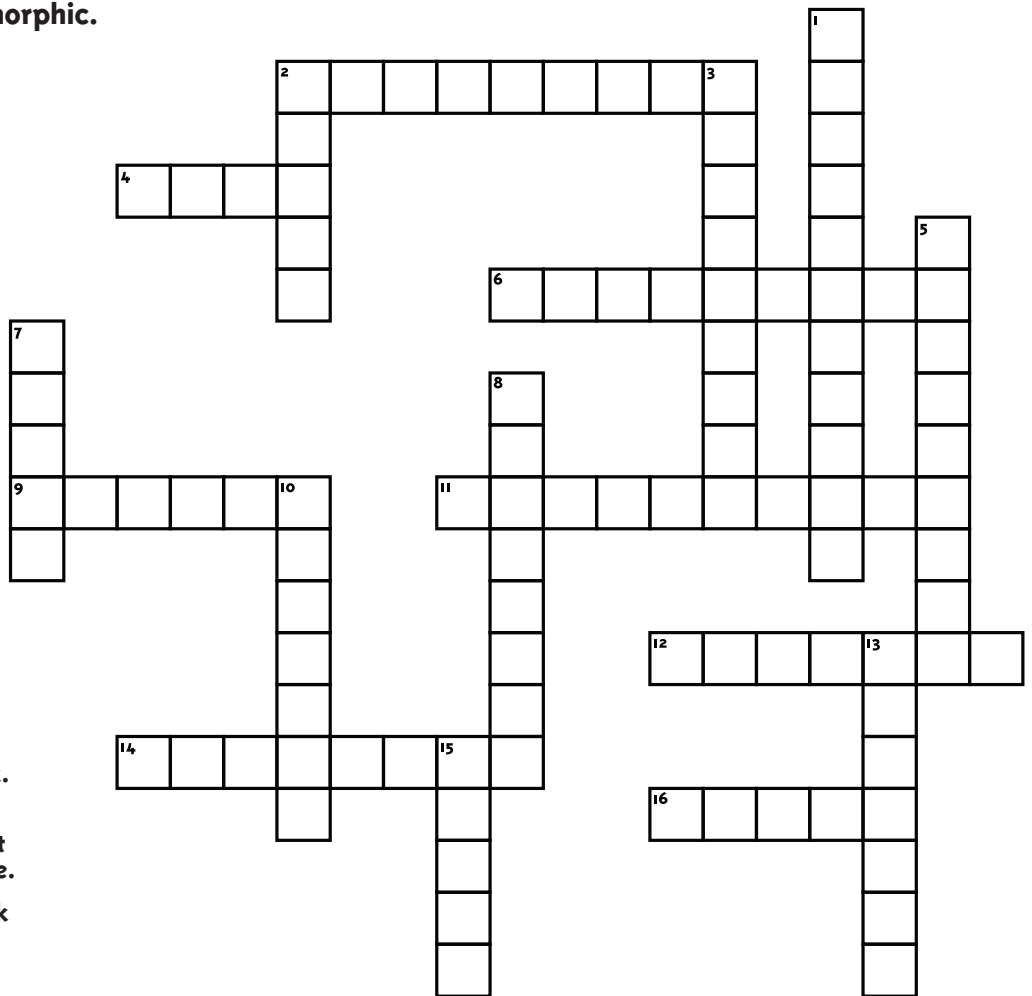

Symbol Sudoku

Fill in the grid so that every row, every column and every 3 x 3 box contains each of the nine symbols below **ONLY ONCE**.

SYMBOLS



Safety Glove

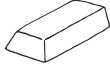

Gold Bar



Diamond



Ore Cart



Safety Boot



Hard Hat



Rock Hammer



Magnifying Glass



Quartz

Periodic Table Spelling Bee

Elements are the basic building blocks of everything around us. They can be found either in their pure form or chemically combined with other elements to make compounds.

Minerals are elements or compounds that occur naturally in the Earth's crust. Rocks are mixtures formed of minerals.

How many words can you spell from the 118 element symbols? Challenge yourself to make three-letter, four-letter, five-letter and even six-letter words.

Hydrogen H																	Helium He				
Lithium Li	Beryllium Be															Boron B	Carbon C	Nitrogen N	Oxygen O	Fluorine F	Neon Ne
Sodium Na	Magnesium Mg															Aluminum Al	Silicon Si	Phosphorus P	Sulfur S	Chlorine Cl	Argon Ar
Potassium K	Calcium Ca	Scandium Sc	Titanium Ti	Vanadium V	Chromium Cr	Manganese Mn	Iron Fe	Cobalt Co	Nickel Ni	Copper Cu	Zinc Zn	Gallium Ga	Germanium Ge	Arsenic As	Selenium Se	Bromine Br	Krypton Kr				
Rubidium Rb	Strontium Sr	Yttrium Y	Zirconium Zr	Niobium Nb	Molybdenum Mo	Technetium Tc	Ruthenium Ru	Rhodium Rh	Palladium Pd	Silver Ag	Cadmium Cd	Indium In	Tin Sn	Antimony Sb	Tellurium Te	Iodine I	Xenon Xe				
Caesium Cs	Barium Ba	LANTHANIDES *	Hafnium Hf	Tantalum Ta	Tungsten W	Rhenium Re	Osmium Os	Iridium Ir	Platinum Pt	Gold Au	Mercury Hg	Thallium Tl	Lead Pb	Bismuth Bi	Polonium Po	Astatine At	Radon Rn				
Francium Fr	Radium Ra	ACTINIDES **	Rutherfordium Rf	Dubnium Db	Seaborgium Sg	Bohrium Bh	Hassium Hs	Meitnerium Mt	Darmstadtium Ds	Roentgenium Rg	Copernicium Cn	Ununtrium Uut	Flerovium Fl	Ununpentium Uup	Livermorium Lv	Ununseptium Uus	Ununoctium Uuo				

*	Lanthanum La	Cerium Ce	Praseodymium Pr	Neodymium Nd	Promethium Pm	Samarium Sm	Europium Eu	Gadolinium Gd	Terbium Tb	Dysprosium Dy	Holmium Ho	Erbium Er	Thulium Tm	Ytterbium Yb	Lutetium Lu
**	Actinium Ac	Thorium Th	Protactinium Pa	Uranium U	Neptunium Np	Plutonium Pu	Americium Am	Curium Cm	Berkelium Bk	Californium Cf	Einsteinium Es	Fermium Fm	Mendelevium Md	Nobelium No	Lawrencium Lr



THREE LETTERS

C At

FOUR LETTERS

K I Te

FIVE LETTERS

S Po O N

SIX LETTERS

Cl O U Dy

Careers

A career in mining is more than you think! There are over 120 different careers in the mining industry. Discover a world of opportunities.



Can you unscramble the careers described below?

SCRAMBLE

1. LOOSEGGIT _____
2. EINM ENIRNEEG _____
3. CRETILNIACE _____
4. OADMIDN IDLRERL _____
5. TNNUACCTOA _____
6. YETFSA TSRNEPICO _____
7. REANLVMOINTNE ICESTSTNI _____
8. IYPSOCTEHIGS _____
9. EPSPCRRTOO _____
10. LEBSTRA _____
11. AWYELR _____
12. EALLTGURISMT _____
13. EIETQPUNM ROTEORPA _____
14. EAHVY UYDT NIMCEHAC _____
15. PUTRMECO ATSESIPLIC _____
16. STIHCME _____
17. MNAREILS VRUESRYO _____



CAREER

- Evaluates the geological aspects of mine sites
- Designs plans for mine sites and mining operations
- Repairs a variety of electrical equipment
- Uses a drill with a diamond tipped bit to bore deep holes
- Manages the money spent by the company
- Visits the mine to ensure safe working conditions
- Ensures that the mine operations follow environmental guidelines
- Interprets geophysical data to locate mineral reserves
- Searches for valuable mineral deposits
- Blasts large rocks and other surfaces for mining
- Obtains permits, rights and licenses
- Supervises the extraction of metals from ores
- Operates equipment used in daily mine operations
- Repairs and maintains heavy duty equipment
- Maintains and operates robots and computer networks
- Analyzes samples collected daily from the mine
- Maps and develops plans for sites of mineral extraction



WORD BANK

- | | | |
|---------------------|-------------------------|-------------------|
| ACCOUNTANT | ENVIRONMENTAL SCIENTIST | METALLURGIST |
| BLASTER | EQUIPMENT OPERATOR | MINE ENGINEER |
| CHEMIST | GEOLOGIST | MINERALS SURVEYOR |
| COMPUTER SPECIALIST | GEOPHYSICIST | PROSPECTOR |
| DIAMOND DRILLER | HEAVY DUTY MECHANIC | SAFETY INSPECTOR |
| ELECTRICIAN | LAWYER | |

Answers

Navigate to the Surface

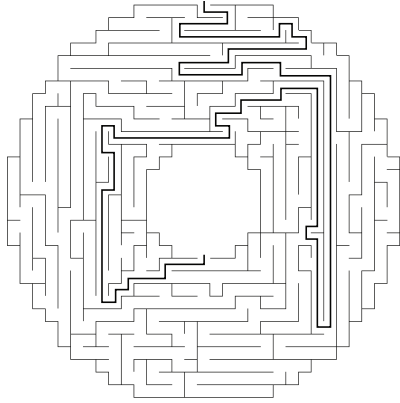

Safety Dress Up

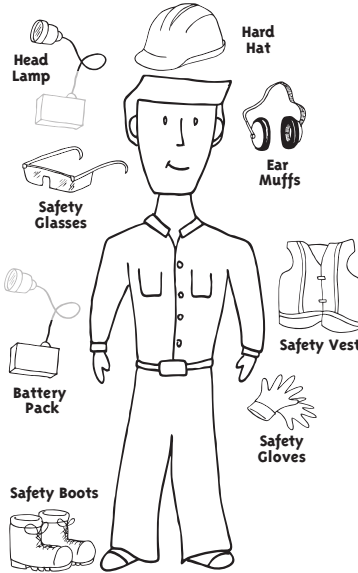

Dig Deep



Mineral Properties

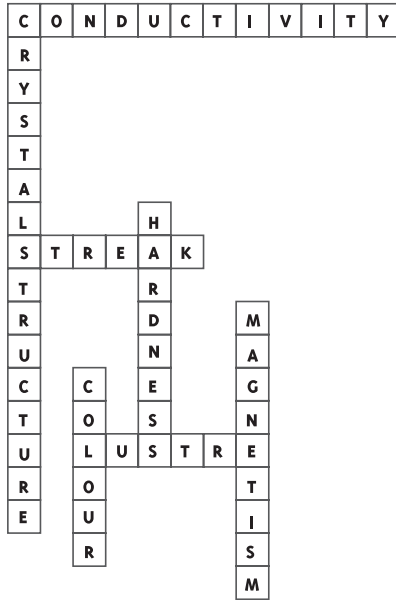

Wordoku

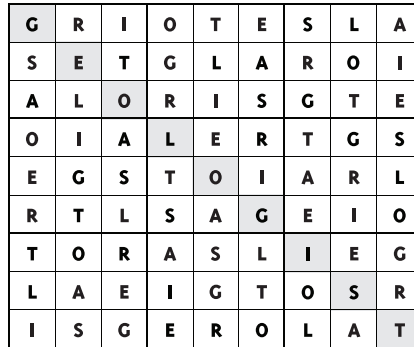

Compass Code Puzzle

**IF IT IS NOT
GROWN
IT IS MINED**

Patty the Prospector

IN ORDER OF USE:

- EARTH DETECTIVE
- GOLD
- GPS
- WOODS
- ROCK HAMMER
- SAFETY GLOVES
- ADVENTURE

Minerals for our Bodies

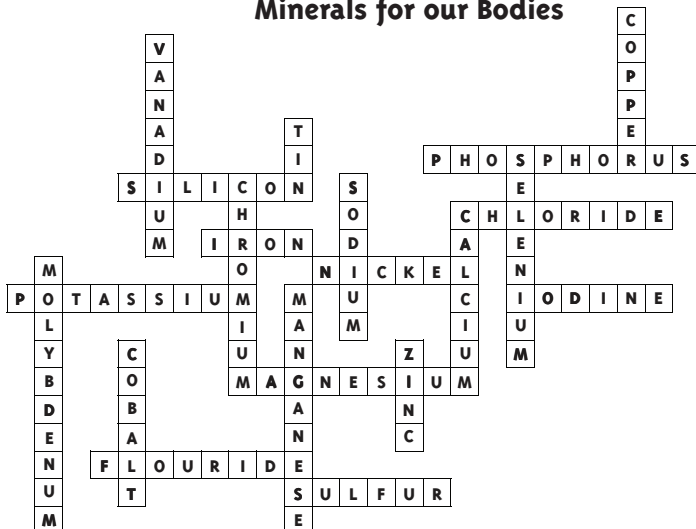

Connect the Dots

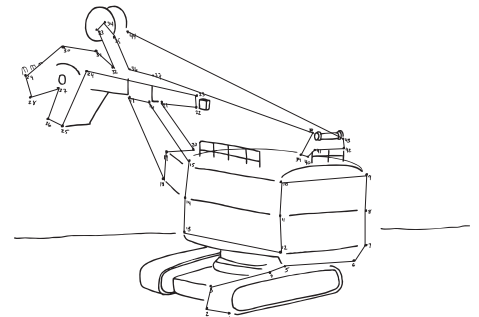

The Mining Process

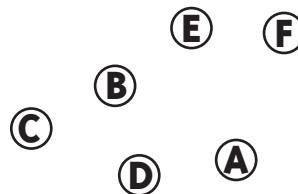

Answers

Hidden Word Sudoku

1	2	3	6	8	4	7	5	9
4	5	6	7	1	9	2	8	3
7	8	9	3	5	2	6	1	4
3	9	5	4	2	6	8	7	1
6	7	8	1	9	5	4	3	2
2	4	1	8	7	3	5	9	6
8	3	7	2	6	1	9	4	5
9	6	4	5	3	8	1	2	7
5	1	2	9	4	7	3	6	8

R O C K C Y C L E

Product Matching

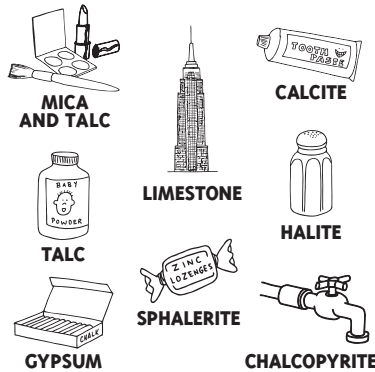

What's in your Computer?

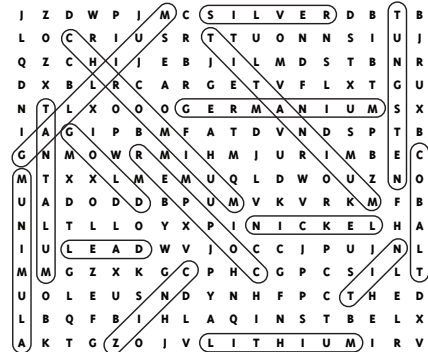

Word Jumble

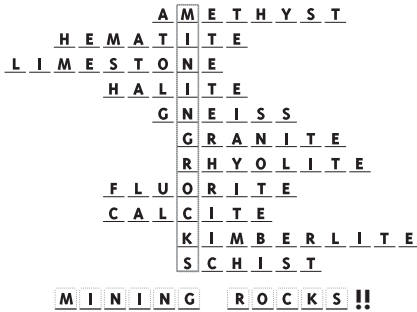

Gemstone Month



Rocks, Minerals, Metals and Mining Word Search

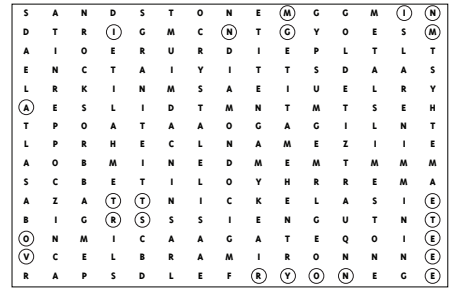

Spot the Differences

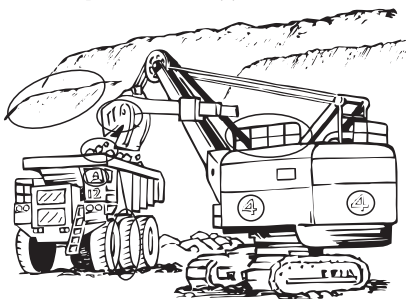

Symbol Sudoku

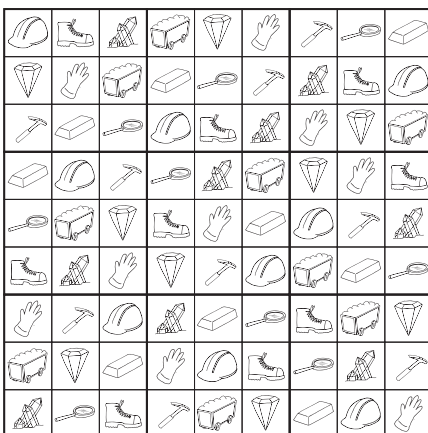

Rock Cycle Crossword

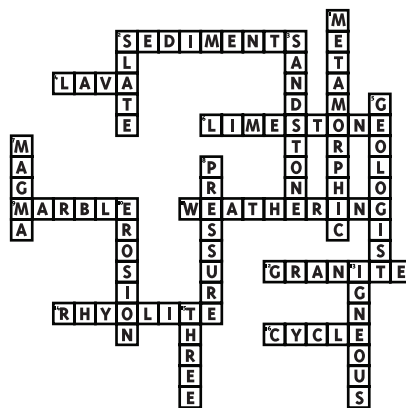

Careers

- Geologist
- Mine Engineer
- Electrician
- Diamond Driller
- Accountant
- Safety Inspector
- Environmental Scientist
- Geophysicist
- Prospector
- Blaster
- Lawyer
- Metallurgist
- Equipment Operator
- Heavy Duty Mechanic
- Computer Specialist
- Chemist
- Minerals Surveyor

Acknowledgements

Produced by Mining Matters
Illustrated by Stephan Baker
Graphic Design by Minke Design

Compliments of

KINROSS

